

> PRODUCT FUNCTIONS DESCRIPTION

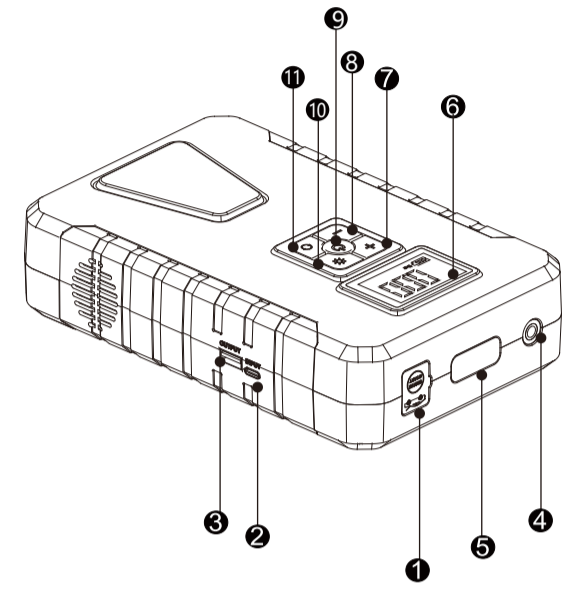

- ① 12V Start Output
- ② TYPE-C Input:5V/1.5-2.0A
- ③ USB Output:5V/1.0A
- ④ Inflatable port
- ⑤ LED灯 (Lighting/Flash/SOS)
- ⑥ LED Display
- ⑦ + Plus key
- ⑧ - Plus key
- ⑨ Power/air pump start key
- ⑩ Lighting switch
- ⑪ Setting key

1

> TECHNICAL SPECIFICATIONS

- ▶ Product Model: TM16F
- ▶ Product Size: 220*140*55mm
- ▶ Output Jump Starter: 12V
- ▶ USB Output: 5V/1.0A
- ▶ Input: 5V/1.5-2.0A
- ▶ Starting Current: See product capacity for details
- ▶ Peak Current: See product capacity for details
- ▶ Cycle Life: >3000times
- ▶ Operating Temp: -20-60°C
- ▶ Gauge Scale: PSI and kg/cm²
- ▶ Pump Time: 40psi
- ▶ Displacement: 30liter per minute (Test done in 0KG/CM²)

> CONTENTS

- ▶ Jump starter X1
- ▶ Packing box X1
- ▶ 1 in 1 mobile cable X1
- ▶ Juper cable X1
- ▶ User manual X1
- ▶ Inflatable tube X1

Details are subject to delivery

2

> ACCESSORY CABLES

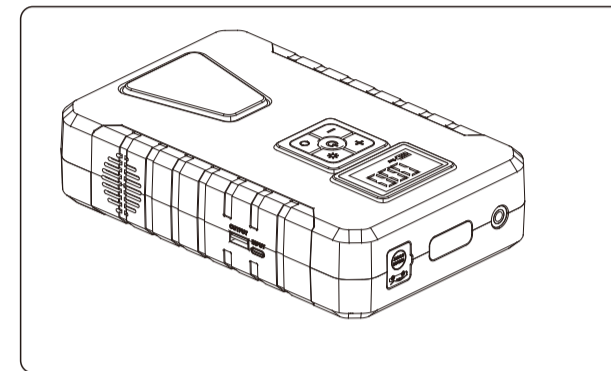

Jump starter X1

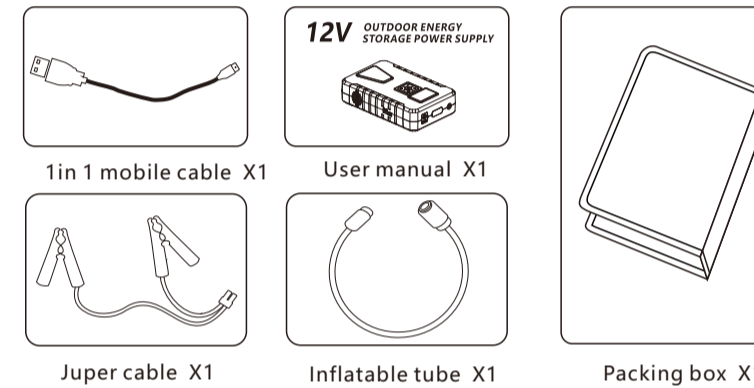

3

> OPERATING INSTRUCTIONS

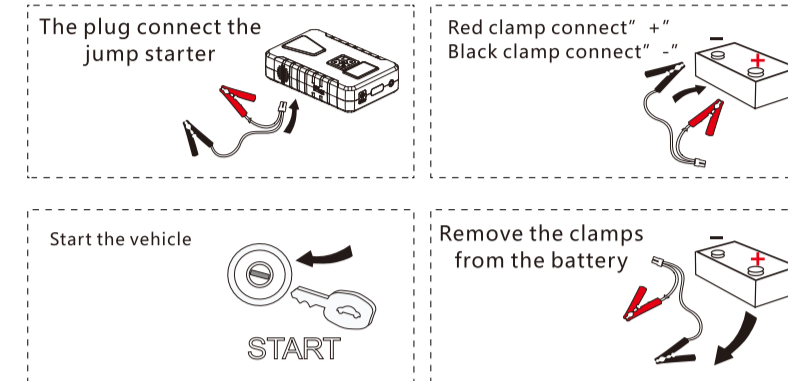

STARTING A CAR WITH THE JUMP STARTER

- 1.Connect the Jumper Cables to the Jump Starter by plugging the connector into the Jump Starter Socket. Make sure the blue plug is FIRMLY inserted into the jump starter.
- 2.Connect the RED Battery Clamp to the Positive(+) battery terminal and connect the BLACK Battery Clamp to the Negative(-) battery terminal. Make sure the battery clamps make good clean contact with the battery terminals.
- 3.Slide the Jump Starter ON/OFF switch to the ON position.
- 4.Start the car.
- 5.Once the car has started, remove the jumper cables from the battery WITHIN 30 seconds (failure to do so may damage the jump starter) and leave the engine running.

4

> OPERATING INSTRUCTIONS

- ▶ Manual: Access to the air pump end pipe → Start air pump → Access to the tire end of the trachea → Full stop

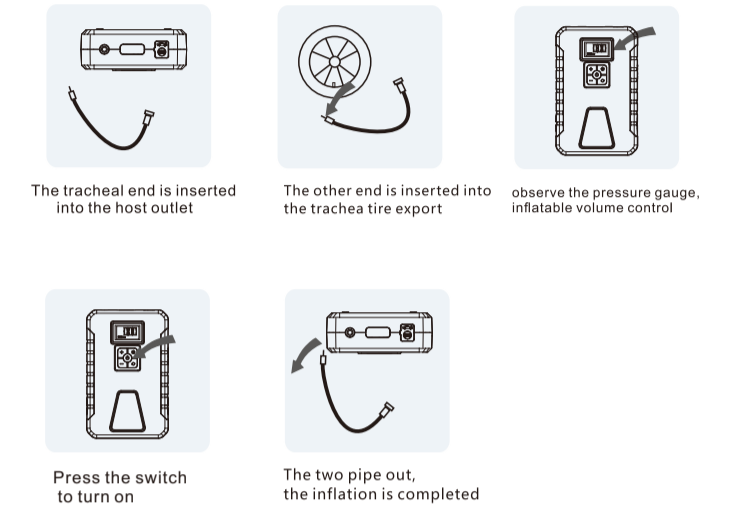

- ▶ It takes about 3-4 hours to charge the startup power supply.
- ▶ Turn the main power switch to ON, Tap Ⓚ.
- ▶ You can charge your phone's tablet

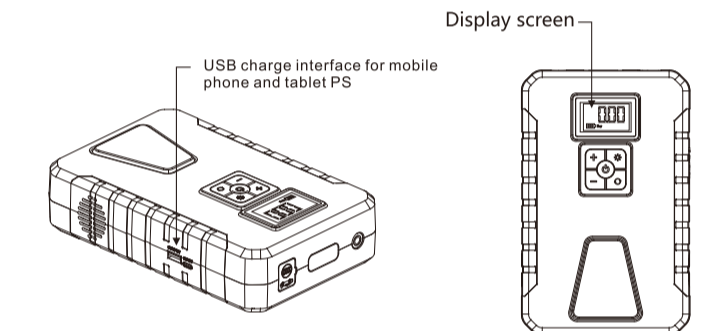

5

> Frequently Asked Questions

Problem1:After a few seconds of successful start-up, it automatically turns off or after removing the clip
This situation is generally due to the excessive use of the car battery or serious aging caused, you can try to start again after running for 3 minutes to charge the battery, if this is still the case, it means that the battery has no power storage capacity, you must replace the new battery.

Problem2:Charging is not charged.

1. Check whether the display shows "IN", then "%" flashes, if neither is displayed, please check whether the charger connection is normal.
2. Please check whether the charging cable is correctly connected to the charger and whether there is power on the mains socket; You can try replacing a charger or charging cable and try again (this power supply You can use the phone's charger and cable directly).

Problem3:You can't charge your phone

Check that the USB output of the boot power supply is turned on, and the power is at least one block or more than 10%. Check that the charging cable is properly connected or damaged, and if necessary, please replace the charging cable and try again

Problem4: Can't start the car

The engine is completely in motion at start-up, first check whether the clips are reliably connected, if the battery cable head is dirty or badly rusted, please clean it up and try again. If it is determined that it has been connected, it is possible that the car has entered a protected state, and some models can try to press and hold the start button directly for about 10 seconds, waiting until the engine is moving. The engine moves at start-up, but it does not start, please check whether the clip is reliably connected to the copper head of the battery line, if the negative electrode is attached to the iron shell of the car, it will affect the starting performance.

The above answer if not solve the problem, Please contact customer service to analyze and solve, do not disassemble the machine!

Certificate
Examine: _____
Date: _____

6

封底

> Warranty card

This product provides customers with a warranty service of 12 months from the date of purchase

Guarantee conditions: When you need warranty service, please present this warranty card and fill in the relevant content in detail. The Company provides

Warranty Coverage:

1. Product quality problems occur in the normal state of use.
2. If the damage to the product is caused by the operation error, it is not covered by the warranty.
3. After disassembling the machine, no warranty will be granted.
4. Confirm that this tamper evident label is complete, if the word (VOID) appears, it means that it has been opened and no warranty will be granted.

Products that are not covered by warranty, our company can provide maintenance services, and the maintenance costs need to be borne by the

Product model	Factory number
Date of purchase	Repair date
Customer name	Contact number
Customer address	
Sales units	
Description of product anomalies	

7

> WARNINGS

- > This machine is only suitable for general car tires, and can not be used for large and heavy cars.Vehicle tires, such as trucks, trucks, container trucks, etc.
- > Inflatable period or end, the outlet will produce high temperature, please be careful to scald!

1. When using the Jump Starter make sure the blue plug is FIRMLY inserted into the Jump Starter. IF NOT, the jump starter will not start your car AND this may cause damage to the jump starter.
2. Make sure the battery clamps make good clean contact with the battery terminals. IF the jump starter fails to start your car after 3 attempts, stop and check for other possible problems.
3. Remove the clamps from the battery terminal within 30 seconds after starting your car. Failure to do so may damage the jump starter.
4. DO NOT connect the two battery clamps together. Doing so is not only dangerous but will also damage the jump starter and void your warranty.
5. Make sure the jump starter has over 80% power when using to starting the car.

Warning:

1. When charging the product, please stay away from the sofa, curtains and other flammable and explosive items to avoid causing safety accidents.
2. It is prohibited to use automobile emergency start and export for a long time, otherwise it is easy to use automobile emergency start and export for a long time.
3. Cause the battery pack to overdischarge and damage the battery.
4. If it is not used for a long time, charge and discharge the product for at least three months
5. Once to avoid overdischarge of the battery pack
6. please store the products in a cool and ventilated place and stay away from flammable and explosive materials
7. Products, do not be exposed to the sun or stored in high temperature
8. Please do not disassemble the mainframe by yourself, please put it out of reach of children
9. To avoid causing a safety accident

8

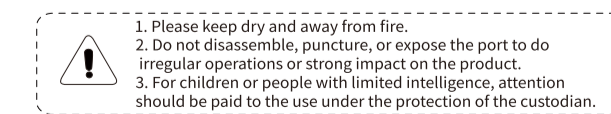

1. Please keep dry and away from fire.
2. Do not disassemble, puncture, or expose the port to do irregular operations or strong impact on the product.
3. For children or people with limited intelligence, attention should be paid to the use under the protection of the custodian.

12V^{TM16F} MULTI-FUNCTION OUTDOOR ENERGY STORAGE POWER SUPPLY

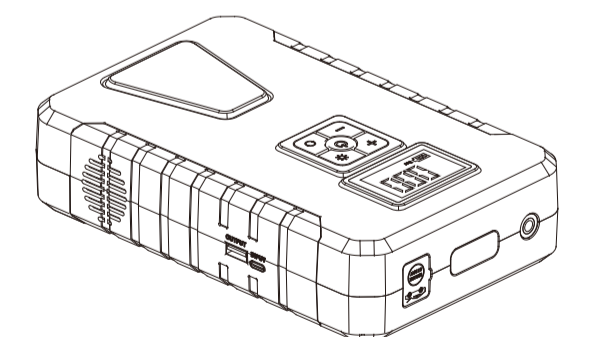

Tips

Please read this instruction manual carefully and follow the instructions for proper use of this product.

封面